

990 Vibration Transmitter

Datasheet

Bently Nevada Machinery Condition Monitoring

141612 Rev. R

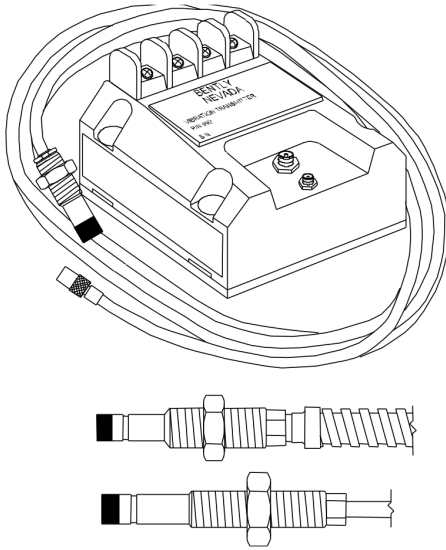

Description

The 990 Vibration Transmitter is intended primarily for the original equipment manufacturers (OEMs) of centrifugal air compressors or small pumps, motors, or fans who prefer to provide a simple 4 to 20 mA proportional vibration signal as the input to their machinery control system.

The transmitter is a two-wire, loop-powered device that accepts input from our 3300 NSv proximity probe and its matching extension cable (available in 5 m and 7 m system length options).

The transmitter conditions the signal into appropriate peak-to-peak vibration amplitude engineering units, and provides this value as a proportional 4 to 20 mA industry-standard signal as the input to the control system where machinery protection alarming and logic occurs†.

The 990 transmitter provides the following notable features:

- Integrated Proximator Sensor requires no external unit
- Non-isolated "PROX OUT" and "COM" terminals plus a coaxial connector to provide a dynamic vibration and gap voltage signal output for diagnostics‡.
- Non-interacting zero and span potentiometers under the Transmitter label supports loop adjustment.
- Test Input pin for quick verification of loop signal output, using a function generator as the input.
- A Not OK/Signal Defeat circuit prevents high outputs or false alarms due to a faulty proximity probe or loose connection.



- Choice of DIN-rail clips or bulkhead mounting screws as standard options simplifies mounting.
- Potted construction for high humidity (up to 100% condensing) environments. Compatibility with 3300 NSv proximity probe allows transducer installation in small areas with minimal clearance, typical of centrifugal air compressors.

Notes

† Vibration transmitters have many limitations when compared to a continuous vibration monitoring system. They are a practical solution in some applications for measuring general vibration levels and are a valuable tool for overall vibration trending. However, they provide limited capability for machinery diagnostics using the vibration signal and do not capture dynamic vibration signals (used for diagnostics) in the event of a vibration alarm. While the transmitter is capable of peak vibration alarming and non-OK checking, the 4-20 mA signal cannot be used to determine the phase of vibration, and monitor functions such as gap alarms, phase alarms, Timed OK channel defeat, Danger Bypass, and Trip Multiply cannot be used. In addition, PLCs attached to the vibration transmitter can only provide peak-to-peak trending data and are not suitable for plant-wide diagnostic systems such as System 1 or Rule Paks.

‡ The 990 Vibration Transmitter's "Prox Out" coaxial connector provides a non-isolated dynamic transducer signal for machinery diagnostics. You can connect this signal directly to battery-powered or isolated test equipment to diagnose machinery problems. However, since the "PROX OUT" signal is not isolated from the 4 to 20 mA loop signal, an interface is available (and strongly recommended) for signal isolation. The 990/991 Test Adapter conditions the 990 Transmitter's "PROX OUT" signal for use with ac-powered test equipment. It also inverts and isolates the 990's transducer signal, making it suitable for equipment such as oscilloscopes and analyzers, and preserving industry-standard conventions for signal polarity. We strongly

recommend the use of this test adapter for all applications to maintain isolation between test equipment and the loop signal, and ensure that the installation maintains machinery protection integrity.

Specifications

Unless otherwise noted, the following specifications apply at +22 °C (+72 °F) using a 3300 NSv Probe and Extension Cable, and an AISI 4140 steel target.

 These specifications also apply to 990 with modifications 147202-01 (RMOD 4140 3300XL 8MM 5M) and 165335-01 (MOD 4140 3300 XL 8MM 9M).

Electrical

Input	Accepts 1 non-contacting 3300 NSv Proximity Probe and extension cable.
Power	Requires +12 to +35 Vdc input at the transmitter terminal.
4 to 20 mA signal output	4 to 20 mAdc over specified full-scale range in 2-wire configuration.
4 to 20 mA loop accuracy	Within ±1.5% over specified full-scale range. Accuracy is rated from the TEST signal input to the voltage measured across a 250 Ω loop resistance. The ±1.5% error is in addition to the Prox Out Incremental Scale Factor.
Probe gap	Probe must be gapped between 0.5 and 1.75 mm (20 and 55 mils) from target to ensure full scale range.
Maximum loop resistance	1,000 Ω including cable at 35 Vdc.
Current limiting	23 mA typical.
Zero and span	Non-interacting external adjustments.
NOT OK/signal defeat	Signal output will go to less than 3.6 mA within 100 μs after a Not OK condition occurs. Signal output is restored within 2-3 seconds after the Not OK condition is removed.

Power-up inhibit	Signal output stays at less than 3.6 mA (NOT O.K.) for 2 to 3 seconds after power is applied. The purpose is to signal that the device is not yet ready. Transients may be observed when device goes O.K.			
Proximitor sensor output	Compatible with ungrounded, portable test equipment. When using grounded, ac-powered test equipment, use the 122115-01 Test Adapter for signal isolation.			
Output impedance	Prox Out has a 10 kΩ output impedance calibrated for a 10 MΩ load.			
Prox out linear range	1.4 mm (55 mils). Begins at approximately 0.25 mm (10 mils) from target surface.			
Prox Out incremental scale factor	7.87 mV/μm (200 mV/mil) ± 6.5% typical including interchangeability errors when measured in increments of 0.25 mm (10 mils) over the linear range using a flat 30 mm (1.2 inch) target. Worst case 7.87 mV/μm ± 10%. Typical Noise Level: 50 mV/pp.			
Temperature stability	Incremental scale factor remains within ±10% of 7.87 mV/μm (200 mV/mil) from 0 °C to +70 °C (+32 °F to +158 °F).			
Frequency response	5 Hz to 6,000 Hz +0, -3 dB.			
Minimum target size	9.5 mm (0.375 in) diameter.			
Leadwire length	Maximum for Proximitor Sensor Output (BNC connector), maximum cable distance is 3 metres (10 feet).			
Non-Hazardous, Zone 2 or Div 2 Hazardous area locations	Power Supply: 28V			
Intrinsically Safe Hazardous area locations	<p>Zone 0/1</p> <table border="1"> <tr> <td>Terminal blocks E1-E2 "power supply"</td> <td>Terminal blocks E3-E4 and connector J2</td> <td>Connector J3 "Probe"</td> </tr> </table>	Terminal blocks E1-E2 "power supply"	Terminal blocks E3-E4 and connector J2	Connector J3 "Probe"
Terminal blocks E1-E2 "power supply"	Terminal blocks E3-E4 and connector J2	Connector J3 "Probe"		

	4-20 mA"	"Proximitor"	
	Ui [28 V	Uo [28 V	Uo [28 V
	Ii [120 mA	Io [6 mA	Io [100 mA
	Pi [0.84 W	Po [0.17 W	Po [0.8 W
	Ci [20 nF	Co [80 nF	Co [27.3 nF
	Li [10 μH	Lo [1H	Lo [5.3 mH
Electrical classification	General Purpose Approval by Canadian Standards Association (CSA/NRTL/C) in North America and by VDE in Europe. 990 has the CE mark for Europe		

Maritime Approvals

American Bureau of Shipping (ABS) Type Approval	Certification Number: 06-HS177078-3-PDA
---	---

Environmental Limits

Transmitter Temperature	
Operating temperature	-35°C to +85°C (-31°F to +185°F)
Storage temperature	-52°C to +100°C (-62°F to +212°F).
Probe Temperature	
Operating temperature	-52°C to +177°C (-62°F to +351°F)
Storage temperature	-52°C to +177°C (-62°F to +351°F)
Relative humidity	100% condensing, non-submerged, with protection of coaxial connectors.

Mechanical

Transducer tip material	Polyphenylene sulfide (PPS).
Transducer case material	AISI 303 or 304 Stainless Steel (SST).
Probe Cable	75Ω coaxial, fluoroethylene propylene (FEP) insulated.
Cable armor (optional)	Flexible AISI 302 SST with optional FEP outer jacket.
Tensile strength	222 N (50 lbf) probe case to probe lead, maximum.
Transmitter weight	0.43 kg (0.9 lbm).
Total system weight	0.82 kg (1.8 lbm) typical.

Compliance and Certifications

FCC

This device complies with part 15 of the FCC Rules. Operation is subject to the following two conditions:

- This device may not cause harmful interference.
- This device must accept any interference received, including interference that may cause undesired operation.

EMC

EN 61000-6-2

EN 61000-6-4

EMC Directive 2014/30/EU

ATEX

ATEX Directive 2014/34/EU

RoHS

RoHS Directive 2011/65/EU

Maritime

ABS 2009 Steel Vessels Rules

1-1-4/7.7,4-8-3/1.11.1,4-9-7/13

Hazardous Area Approvals



For the detailed listing of country and product specific approvals, refer to the *Approvals Quick Reference Guide* (108M1756) available from Bently.com.

CSA/NRTL/C

Class I, Div 2
 Groups A, B, C, D
 T5@ Ta [+85°C, Type 4
 Installed per Drawing 128838

ATEX/IECEx

II 1 G Ex ia IIC T4 Ga T4 @ Ta = -35°C to +85°C
II 3 G Ex nA IIC T4 Gc T4 @ Ta = -35°C to +85°C

Entity Parameters

Zone 2

Power Supply: 28V

Zone 0/1

Terminal blocks E1-E2 "power supply 4-20 mA"	Terminal blocks E3-E4 and connector J2 "Proximator"	Connector J3 "Probe"
Ui [28 V	Uo [28 V	Uo [28 V
Ii [120 mA	Io [6 mA	Io [100 mA
Pi [0.84 W	Po [0.17 W	Po [0.8 W
Ci [20 nF	Co [80 nF	Co [27.3 nF
Li [10 µH	Lo [1H	Lo [5.3 mH

Ordering Information



For the detailed listing of country and product specific approvals, refer to the *Approvals Quick Reference Guide* (108M1756) available from Bently.com.

990-AA-BB-CC-DD

A: Full-scale Option

04 0-4 mils pp (0-100 µm pp)

05 0-5 mils pp (0-125 µm pp)

B: System Length Option

50 5.0 metres (16.4 feet)

70 7.0 metres (23.0 feet)

C: Mounting Option

01 35 mm DIN rail clips

02 Bulkhead screws

03 DIN clips and screws

D: Agency Approval Option

00 Not required

01 CSA Division 2

05 CSA Division 2, ATEX Zone 0, ATEX Zone 2 and includes ABS maritime approval

3300 NSv Proximity Probes, Standard

Part Number-AA-BB-CC-DD-EE

330901 3300 NSv Probe, 1/4-28 UNF thread, without armor.

330902 3300 NSv Probe, 1/4-28 UNF thread, with armor.

330908 3300 NSv Probe, 3/8-24 UNF

thread, without armor.

330909 3300 NSv Probe, 3/8-24 UNF thread, with armor.

A: Unthreaded Length Option



Unthreaded length must be at least 0.7 inches less than the case length.

Order in increments of 0.1 in

Length configurations

Minimum length: 0 in

Maximum length: 9.2 in

Example: **04** = 0.4 in

B: Case Length Option

Order in increments of 0.1 in

Minimum length: 0.8 in

Maximum length: 9.9 in

Example: **35** = 3.5 in

C: Total Length Option

05 0.5 metre (1.67 feet)

10 1.0 metre (3.25 feet)

50 5.0 metres (16.4 feet)

70 7.0 metres (23 feet)

D: Connector Option

01 Miniature coaxial ClickLoc connector with connector protector, standard cable

02 Miniature coaxial ClickLoc connector, standard cable

11 Miniature coaxial ClickLoc connector with connector protector, FluidLoc cable

12 Miniature coaxial ClickLoc connector, FluidLoc cable

E: Agency Approval Option

00	Not required
05	Multiple Approvals (CSA NRTL/C and BASEEFA/CENELEC, which includes CSA Division 2)

3300 NSv Probes, Metric

Part Number-AA-BB-CC-DD-EE

330903	3300 NSv Probe, M8 x1 thread, without armor.
330904	3300 NSv Probe, M8 x1 thread, with armor.
330905	3300 NSv Probe, M10 x1 thread, without armor.
330910	3300 NSv Probe, M10 x1 thread, with armor.

A: Unthreaded Length Option



Unthreaded length must be at least 20 mm less than the case length.

Order in increments of 10 mm

Minimum length: 0 mm

Maximum length: 230 mm

Example **06** = 60 mm

B: Case Length Option

Order in increments of 10 mm

Minimum length: 20 mm

Maximum length: 250 mm

Example: **25** = 250 mm

C: Total Length Option

05	0.5 metre (1.67 feet)
10	1.0 metre (3.25 feet)

50	5.0 metres (16.4 feet)
70	7.0 metres (23 feet)

D: Connector Option

01	Miniature coaxial ClickLoc connector with connector protector, standard cable
02	Miniature coaxial ClickLoc connector, standard cable
11	Miniature coaxial ClickLoc connector with connector protector, FluidLoc cable
12	Miniature coaxial ClickLoc connector attached, FluidLoc cable

E: Agency Approval Option

00	Not required
05	Multiple Approvals (CSA NRTL/C and BASEEFA/CENELEC, which includes CSA Division 2)

3300 NSv Reverse Mount Probe

330906-02-12-CC-DD-EE 3/8-24 UNF threads

330907-05-30-CC-DD-EE M10 x 1 UNF threads

C: Total Length Option

05	0.5 metre (1.67 feet)
10	1.0 metre (3.25 feet)
50	5.0 metres (16.4 feet)
70	7.0 metres (23 feet)

D: Connector Option

02	Miniature coaxial ClickLoc connector, standard cable
12	Miniature coaxial ClickLoc connector attached, FluidLoc cable

E: Agency Approval Option

00	Not required
05	Multiple Approvals (CSA NRTL/C and BASEEFA/CENELEC, which includes CSA Division 2)

Extension Cable

330930-AAA-BB-CC

A: Cable Length Option

040	4.0 metres (13.1 feet)
045	4.5 metres (14.8 feet)
060	6.0 metres (19.7 feet)
065	6.5 metres (21.3 feet)

B Armor Option

00	Without stainless steel armor
-----------	-------------------------------

01	With FEP covered stainless steel armor
02	With stainless steel armor
03	Without stainless steel armor, with connector protector
04	With FEP covered stainless steel armor and connector protector
05	With stainless steel armor and connector protector

C: Agency Approval Option

00	Not Required
05	Multiple Approvals (CSA NRTL/C and BASEEFA/CENELEC (which includes CSA Division 2))

Accessories

122115-01	<p>990/991 Test Adapter. Package includes: 990/991 Test Adapter, 9V battery, Universal AC Adapter, Power Cord (North American), User Guide and Soft Carrying Case.</p> <p>The 990/991 Test Adapter inverts and isolates the PROX OUT signal from the 990 Transmitter so that you can connect 990 Transmitters to AC-powered diagnostic equipment. The Adapter modifies the PROX OUT signal so that it matches our standard Proximitor sensor signals by performing these functions:</p> <ul style="list-style-type: none"> • Shifts the phase of the PROX OUT signal by 180° by changing the voltage from positive to negative • Shifts the phase of the PROX OUT signal by 180° by changing the voltage from positive to negative
-----------	--

	<ul style="list-style-type: none"> Shifts the phase of the PROX OUT signal by 180° by changing the voltage from positive to negative <p>The 990/991 Test Adapter provides the following benefits:</p> <ul style="list-style-type: none"> Small size and weight for portable operation Battery or AC adapter power options Automatic shutoff circuit that powers down the unit when the battery is low 2 channels, so that you can display an orbit for XY probe configurations.
--	--

	4 to 20 mA loop. Also used for the PROX OUT signal on the 990 Transmitter's terminal strip.
123655	990/991 Transmitter System Installation User Guide
330153-05	Cable Connector Kit. Package Includes 1 set of 75 Ω miniature male and female connectors, shrink tubing and 3300 Isolator Seal for protection of coaxial connectors.
163356	Connector Crimp Tool Kit. Includes one set of 75 Ω ClickLoc inserts and connector installation instructions. Supplied with carrying case.
330951-01	990 Mounting Screws (spares). Contains 4 screws.
284726	DIN rail mounting kit. Installed on the 990 Transmitter to allow mounting on 35 mm DIN rail.

990/991 Test Adapter Accessories

123266-01	Coaxial Cable Kit. Includes 4 cables with length of 1.5 metres (5 feet) each.
02211505	Single coaxial cable with length of 1.5 metres (5 feet).

990/991 Test Adapter Spare Parts

01810700	Battery (9 volt alkaline).
02270056	AC adapter. Has universal AC input to 9 volts DC output. Input is 108 to 132 Vac with 120 Vac nominal, or 207 to 253 Vac with 240 Vac nominal.
02198937	Power cord (for North American AC power outlet).
123133	990 Test Adapter User Guide

Probe and Transmitter Accessories

02173006	Bulk cable (specify length in feet). 1.0 mm ² (18 AWG), 2-conductor, twisted, shielded cable used for the
----------	--

Graphs and Figures

All dimensions shown in millimeters (inches) unless noted otherwise

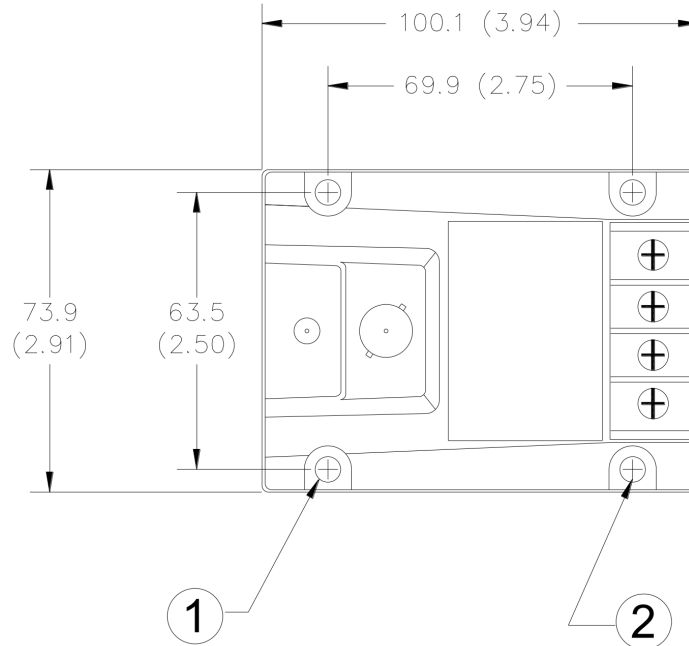

1. Mounting holes, 5.8 mm (0.23 in) diameter, 4 places
2. Bulkhead mount holes, 4 each. 6-32 x 1.326 screws provided when mounting option specified

Figure 1: 990 Vibration Transmitter Dimensions (top view)

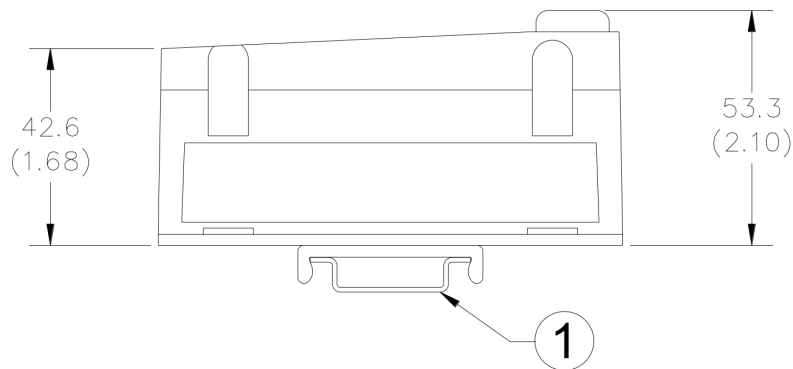

1. 35mm DIN rail DIN mount clips (when DIN rail mounting is specified)

Figure 2: 990 Vibration Transmitter Dimensions (side view)

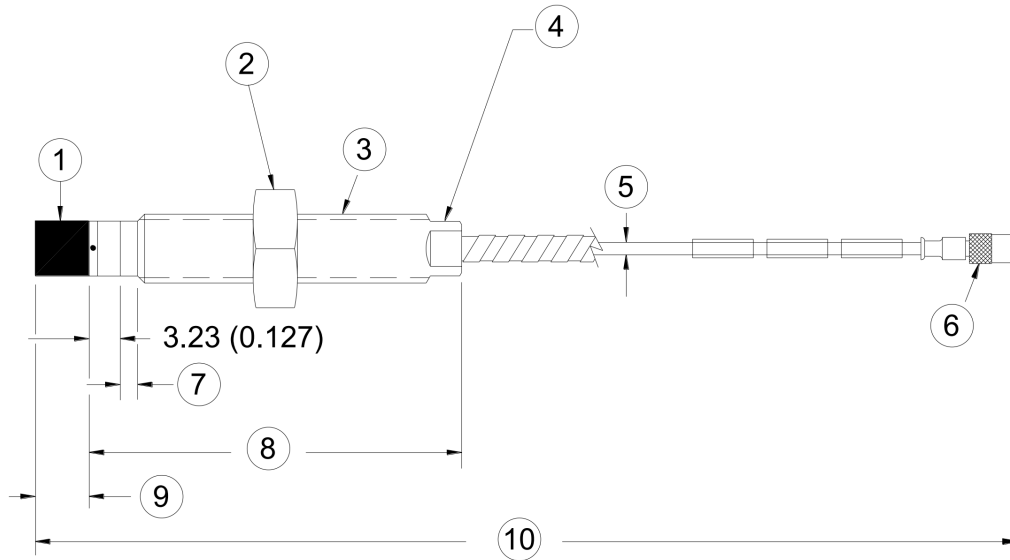

1. Probe tip, 5.26 mm (0.207 in) maximum diameter
2. Hexagonal nut
3. Case Thread
4. Wrench flats
5. 75Ω cable, 2.8 mm (0.11 in) maximum outside diameter, 7.6 mm (0.30 in) maximum outside diameter of armor
6. Miniature male coaxial connector, 7.23 mm (0.285 in) maximum outside diameter "D"
7. Unthreaded length "A"
8. Case length "B"
9. 2.92 mm (0.115 in) maximum
10. Total length "C", +30%, -0%

Figure 3: 3300 NSv Proximity Probes, Standard Mount

Available Probes

- 330901, 1/4-28 UNF-2A, without armor
- 330902, 1/4-28 UNF-2A, with armor
- 330903, M8x1 thread, without armor
- 330904, M8x1 thread, with armor
- 330905, M10x1 thread, without armor
- 330908, 3/8-24 UNF-2A, without armor
- 330909, 3/8-24 UNF-2A, with armor

Standard mounts	Supplied with these wrench flats
1/4-28 UNF thread probes	7/16-inch lock nut and 7/32 inch
M8x1 thread probes	13-mm lock nut and 7 mm.
3/8-28 UNF thread probes	9/16-inch lock nut and 5/16-inch.
M10x1 thread probes	17-mm lock nut and 8 mm.

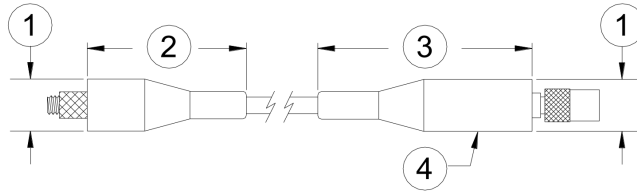

1. 12 mm (0.49 in) maximum diameter
2. 36.3 mm (1.43 in) maximum
3. 51.1 mm (2.01 in) maximum
4. Connector protector (fluorosilicone material)

Figure 4: Installed Connector Protectors

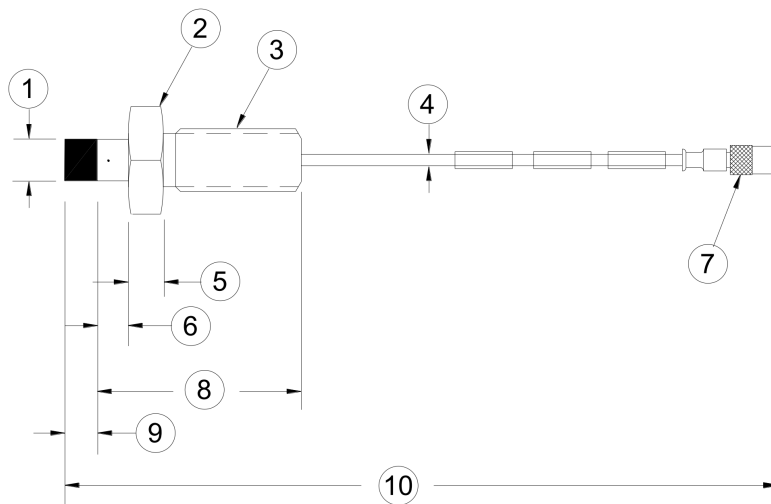

1. Probe tip, 5.26 mm (0.207 in) maximum diameter
2. Hexagonal nut
3. Case thread
4. 75Ω cable, 2.8 mm (0.11 in) outside diameter
5. 5.08 mm (0.20 in)
6. Unthreaded case length "A", 5.08 mm (0.20 in)
7. Miniature male coaxial connector, 7.23 mm (0.285 in) maximum outside diameter "D"
8. Case length "B", 30.48 mm (1.20 in)
9. 2.92 mm (0.115 in) maximum
10. Total length "C", +30%, -0%

Figure 5: 3300 NSv Proximity Probes, Reverse Mount

Available Probes
 330906, 3/8-24 UNF-2A
 330907, M10x1 thread

 Reverse mount probes are not available with armor or connector protector options.

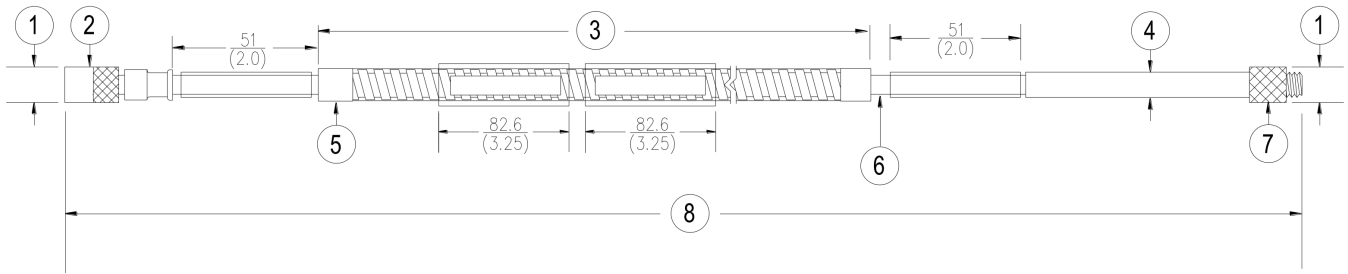

1. 7.2 mm (0.285 in) maximum diameter
2. Miniature male coaxial connector
3. FEP-coated or uncoated armor, armor length is 300 mm (11.8 in) less than cable length
4. 75Ω cable, 2.80 mm (0.11 in) maximum outside diameter, 7.6 mm (0.30 in) maximum outside diameter of armor, 7.0 mm (0.275 in) maximum outside diameter of uncoated armor
5. Stainless steel ferrules, 8.4 mm (0.33 in) diameter
6. FEP-insulated coaxial cable
7. Miniature female coaxial connector
8. Cable length +20%, -0%

Figure 6: 3300 NSv Extension Cable

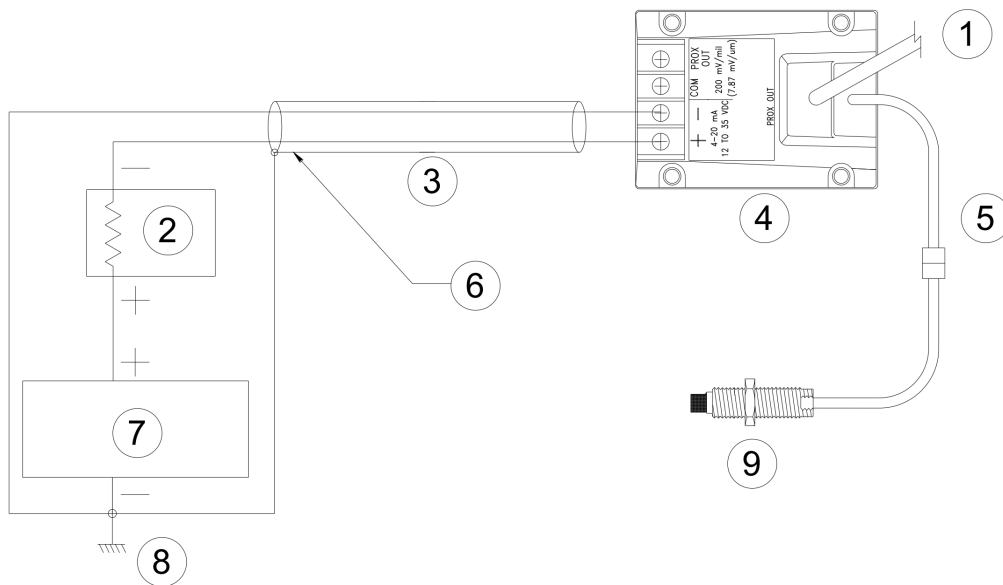

1. To test adapter 122115-01
2. Receiver
3. Cable shield
4. Transmitter
5. Extension cable
6. Recommended wiring is shielded, twisted-pair, 1.0 mm (18 AWG) (part number 02173006).
 Maximum length is 13 km (8 miles).
7. Power supply, $V_{PS} = 17$ to 35 Vdc
8. Common (ground)
9. Probe

Figure 7: 990 Vibration Transmitter Loop Wiring Connections



The phase of the PROX OUT signal is inverted from the standard for Bently Nevada products. Also, connecting grounded AC-powered equipment to PROX OUT may result in a false alarm. Use test adapter 122115-01 to connect AC equipment to the transmitter. Note that the 122115-01 also inverts the PROX OUT signal.

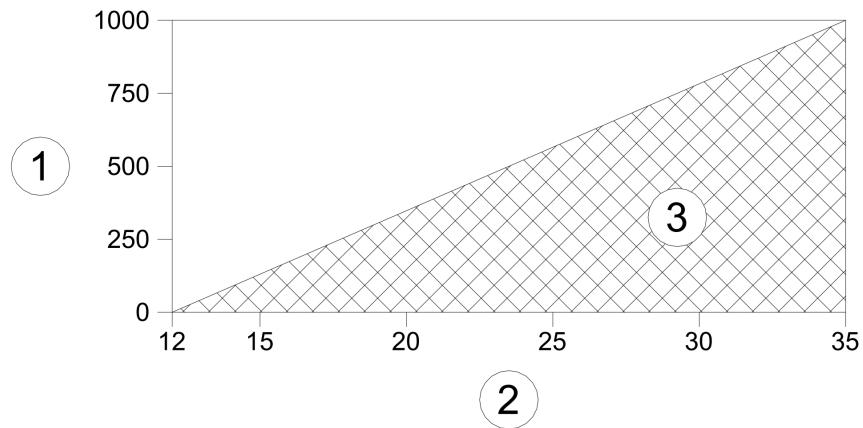

1. Maximum loop resistance in ohms (R_{LOOP})
2. Power supply voltage (V_{PS})
3. Operating region

Figure 8: 990 Vibration Transmitter Maximum Loop Resistance



$R_{LOOP} = 43.5 \times (V_{PS} - 12)$ W maximum. If the maximum loop resistance is exceeded, then the full-scale current does not reach 20 mA.